

CrystalClear™ AC '97 Six Channel Primary ACR Audio Reference Design

Features

- Six Channel Analog Audio Output
- Built-in Headphone Amplifier
- CS4201 audio codec and CS4334 DACs
- 20-bit D to A conversion (DAC)
- 18-bit A to D conversion (ADC)
- S/PDIF (IEC-958) optical digital output
- Complete suite of Analog I/O connections:
 - Line, Mic, CD, Video and Aux Inputs
 - Line Front, and Line Rear Outputs
- 2-layer low cost PC board
- Meets Intel® AC '97 version 2.1 specification
- Exceeds Microsoft's® PC 99 and PC-2001 audio performance requirements.

Description

The CRD4201-2 Advanced Communications Riser (ACR) reference design features six channel analog audio outputs and an optical S/PDIF digital output. This board uses the CS4201 audio codec which has several advanced features such as a built-in headphone amplifier, up to 30 dB of microphone boost, and serial digital audio outputs.

The CRD4201-2 reference design is available by ordering the CMK4201-2 manufacturing kit. This kit includes a full set of schematic design files (OrCAD® 7.2 and OrCAD® 9.1 formats), PCB job files (PADS® ASCII), PCB artwork files, and bill of materials. This reference design offers significant cost savings over competing solutions and can be easily modified to meet your specific design goals.

ORDERING INFO

CMK4201-2 (Manufacturing Kit)

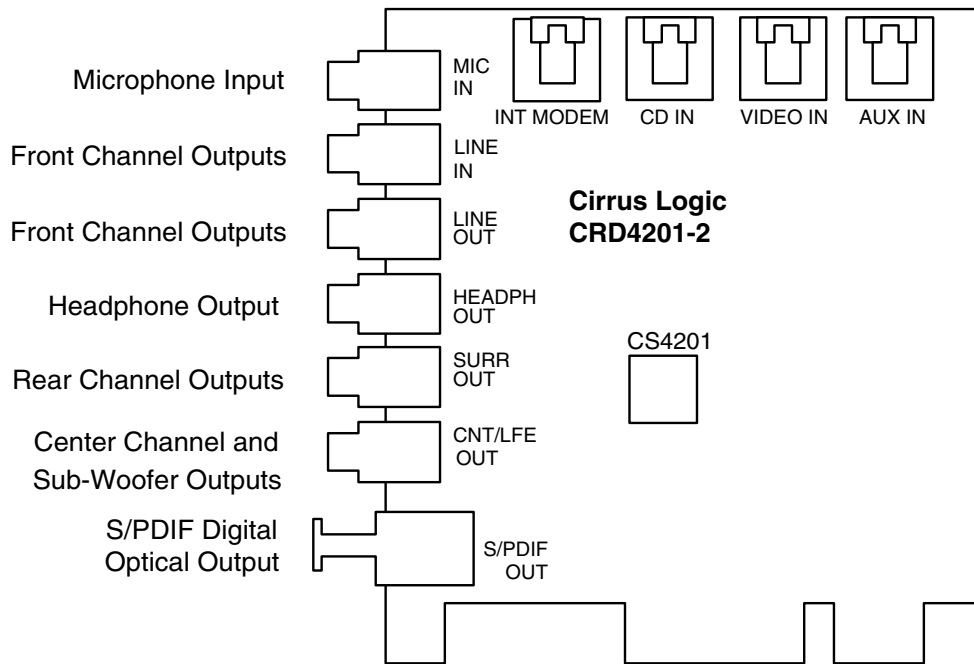

Preliminary Product Information

This document contains information for a new product. Cirrus Logic reserves the right to modify this product without notice.

TABLE OF CONTENTS

1. GENERAL INFORMATION	3
2. SCHEMATIC DESCRIPTION	3
2.1 CS4201 Audio Codec	3
2.2 Analog Inputs	3
2.3 Rear, Center and Sub-Woofer Outputs	4
2.4 Front Channel and Headphone Outputs	4
2.5 S/PDIF Optical Output	4
2.6 ACR Connector and EEPROM	4
2.7 Component Selection	4
2.8 EMI Components	5
3. GROUNDING AND LAYOUT	5
3.1 Partitioned Voltage and Ground Planes	5
3.2 CS4201 Layout Notes	5
4. REFERENCES	6
4.1 ADDENDUM	6
5. BILL OF MATERIALS	19

LIST OF FIGURES

Figure 1. Block Diagram	7
Figure 2. CS4201 Audio Codec	8
Figure 3. Analog Inputs	9
Figure 4. Rear, Center, and Sub-Woofer Outputs	10
Figure 5. Front Channel and Headphone Outputs	11
Figure 6. S/PDIF Optical Output	12
Figure 7. ACR Connector	13
Figure 8. PCB Layout: Top Assembly Drawing	14
Figure 9. PCB Layout: Top Layer	15
Figure 10. PCB Layout: Bottom Layer	16
Figure 11. PCB Layout: Drill Drawing	17
Figure 12. PCB Layout: Top Silkscreen	18

Contacting Cirrus Logic Support

For a complete listing of Direct Sales, Distributor, and Sales Representative contacts, visit the Cirrus Logic web site at:
<http://www.cirrus.com/corporate/contacts/>

Microsoft , Windows 95, Windows 98 and Windows Millennium and WHQL is registered trademark of Microsoft.
CrystalClear is a trademark of Cirrus Logic, Inc.
Intel is a registered trademark of Intel Corporation.
OrCAD is a registered trademark of OrCAD, Inc.
PADS is a registered trademark of, PADS Software, Inc.

Preliminary product information describes products which are in production, but for which full characterization data is not yet available. Advance product information describes products which are in development and subject to development changes. Cirrus Logic, Inc. has made best efforts to ensure that the information contained in this document is accurate and reliable. However, the information is subject to change without notice and is provided "AS IS" without warranty of any kind (express or implied). No responsibility is assumed by Cirrus Logic, Inc. for the use of this information, nor for infringements of patents or other rights of third parties. This document is the property of Cirrus Logic, Inc. and implies no license under patents, copyrights, trademarks, or trade secrets. No part of this publication may be copied, reproduced, stored in a retrieval system, or transmitted, in any form or by any means (electronic, mechanical, photographic, or otherwise) without the prior written consent of Cirrus Logic, Inc. Items from any Cirrus Logic website or disk may be printed for use by the user. However, no part of the printout or electronic files may be copied, reproduced, stored in a retrieval system, or transmitted, in any form or by any means (electronic, mechanical, photographic, or otherwise) without the prior written consent of Cirrus Logic, Inc. Furthermore, no part of this publication may be used as a basis for manufacture or sale of any items without the prior written consent of Cirrus Logic, Inc. The names of products of Cirrus Logic, Inc. or other vendors and suppliers appearing in this document may be trademarks or service marks of their respective owners which may be registered in some jurisdictions. A list of Cirrus Logic, Inc. trademarks and service marks can be found at <http://www.cirrus.com>.

1. GENERAL INFORMATION

The CRD4201-2 reference design is an ACR card that features six channel CD quality analog audio outputs. The card includes a CS4201 AC '97 audio codec and two CS4334 24-bit serial stereo DACs. This combination gives the CRD4201-2 a rich feature set and industry leading audio performance.

The CS4201 on this card is configured as the primary AC '97 audio codec. If there is an AC '97 audio codec on the motherboard, it must be disabled.

The CS4201 audio codec has a stereo 20-bit DAC, a stereo 18-bit ADC, and a very flexible analog audio mixer. The serial data outputs are paired with two CS4334 DACs to provide four additional channels of analog audio. The CS4201 also features three stereo pairs of line level analog inputs, a microphone input, and a stereo pseudo-differential CD input. The input signals can be routed to the ADC for recording or mixed together for recording and direct playback. The CS4201 has internal registers that are used to control its various features such as volume levels, audio muting, and signal routing. The CS4201 maintains high audio quality and exceeds the Microsoft[®] PC-99 and PC-2001 audio performance specification.

The CS4201 audio codec communicates to the audio controller across the ACR interface through the AC-Link. The AC-Link is a 5-wire serial digital interface that transfers digital audio between the two devices and also sends commands from the audio controller to the CS4201's registers. For more information on the AC-Link, see the Intel[®] AC'97 version 2.1 specification.

2. SCHEMATIC DESCRIPTION

The block diagram in Figure 1 illustrates the interconnections between the schematic pages found at the end of this document. Sections 2.1 through 2.8 describe the circuitry contained in these schematics.

2.1 CS4201 Audio Codec

The CS4201 audio codec is shown in Figure 2. The input signals to the CS4201 originate from the analog inputs in Figure 3, and the analog outputs are shown in Figure 5. AFLT1 and AFLT2 (pins 29, 30) require 1000 pF NPO/COG capacitors connected to analog ground. These capacitors provide a single pole lowpass filter at the inputs of the ADC. No other input filtering is required.

FLT3D, FLTI, and FLTO (pins 32, 33, 34) form the internal analog 3D enhancement filter. The FLT3D pin requires a 0.01 μ F capacitor to analog ground. The FLT0 and FLT1 pins require a NPO/COG 1000 pF series capacitor.

The AC-Link may require series termination resistors to prevent reflections. These are normally placed as close as possible to the transmitting end of a particular AC-Link signal. Both SDATA_IN (pin 8) and BIT_CLK (pin 6) are outputs of the CS4201 and each have a 47 Ω series termination resistor.

The CS4201 is powered by separate analog and digital power supplies, each with their own respective grounds. The AGND symbols refer to analog ground, and DGND symbols refer to digital ground. The analog and digital grounds must be connected together. For best results, connect them together at a single point with a 0.050 inch trace underneath the CS4205. Each power pin needs separate decoupling capacitors. The CS4201 audio codec uses a 0.1 μ F ceramic capacitor for each of the 3.3 V digital and 5 V analog supply pins. These decoupling capacitors are placed as close as possible to their respective pins.

2.2 Analog Inputs

The LINE_IN, VIDEO, and AUX_IN stereo input jacks in Figure 3 are connected to a 6 dB voltage divider and AC coupled to the CS4201. The voltage divider allows input signal levels of up to

2 Vrms. The 2.2 μ F AC coupling capacitor values are used to minimize low frequency roll-off.

The microphone circuit is AC coupled by a 1 μ F capacitor to minimize low frequency roll-off. The microphone circuit provides low voltage phantom power for electret microphones. Phantom power is derived from the +5 V analog supply and provides a maximum of 4.2 V under no load and a minimum of 2.0 V under a 0.8 mA load. These parameters are required by PC-99 and PC-2001.

The CS4201 features a pseudo-differential CD input that minimizes common mode noise and interference. Each CD signals acts as one side of the differential input and CD_COM acts as the other side. CD_COM is used as the common return path for both the left and right channels.

2.3 Rear, Center, and Sub-Woofers Outputs

The outputs in Figure 4 drive the rear speakers (surround), center speaker (CNT), and sub-woofer (LFE) in a six channel audio application. These four outputs are driven digitally from the CS4201 through two serial output ports and converted to analog audio through two high-performance CS4334 24-bit stereo DACs.

2.4 Front Channel and Headphone Outputs

Figure 5 details the Headphone Output and Line Output circuits. The Line Outputs are the main analog outputs in a two channel system or the Front Outputs in a six channel audio system.

The Line Outputs of the CS4201 (pins 35 and 36) are buffered by a Motorola MC34072 dual op-amp. The MC34072 is a high performance low noise op-amp well suited for audio applications. Line Out is designed to drive high impedance loads of 10 K Ω or higher.

The CS4201 has a built in headphone amplifier on pins 39 and 41. These outputs are capable of driv-

ing headphones with impedances as low as 32 Ω . The headphone outputs are AC coupled through 220 μ F capacitors. These large capacitor values create excellent low frequency response even under 32 Ω loads.

2.5 S/PDIF Optical Output

The S/PDIF (IEC-958) digital output shown in Figure 6, is compatible with digital outputs on consumer devices such as Mini Disk recorders and consumer stereo receivers. The S/PDIF output operates at a fixed sampling frequency of 48 kHz. It uses an industry standard TOSLINK digital optical transmitter, the Toshiba TOTX-173.

2.6 ACR Connector and EEPROM

The ACR connector is shown in Figure 7. ACR is a motherboard interface that supports audio, modem, LAN, and DSL subsystems. ACR applications are targeted at OEMs, system manufacturers, and system integrators who wish take advantage of physically separating their audio, modem, or LAN circuitry from the PC motherboard. ACR accomplishes this without the additional cost associated with the interface circuitry required for a PCI bus add-in card.

The CRD4201-2 uses a 24LC09 EEPROM to store configuration data for plug-and-play enumeration. The 24LC09 is designed specifically for ACR applications. The base address of the device is internally wired to 0xB0. The EEPROM holds the Subsystem Vendor ID and Subsystem ID. For ACR design specifications, programming utilities, and information on programming the EEPROM see the Advanced Communication Riser Special Interest Group (ACR SIG) homepage at <http://www.acr-sig.org/>.

Note: an ACR signal called PRIMARY_DN# is normally tied to ID0# on the CS4201. This signal is used to set the AC '97 codec on the ACR card as either the primary or secondary audio codec. The CRD4201-2 is designed to have the only audio co-

dec in the system so the PRIMARY_DN# signal trace has been removed.

2.7 Component Selection

Great attention was given to the particular components used on the CRD4201-2 board with cost, performance, and package selection as the most important factors. Listed are some of the guidelines used in the selection of components:

- No components smaller than 0805 SMT package.
- Only single package passive components. No resistor packs. This reduces the risk of crosstalk between analog audio signals.
- All components except connectors, jumpers and the 24.576 MHz crystal are in surface mount packages.
- Dual footprints are used for the 24.576 MHz crystal.

2.8 EMI Components

Optional capacitors and inductors are included to help the board meet EMI compliance tests, such as FCC Part 15. Choose these component values according to individual requirements.

3. GROUNDING AND LAYOUT

The component layout and signal routing of the CRD4201-2 provides a good model for laying out your own ACR add-in card.

3.1 Partitioned Voltage and Ground Planes

It is critical for good audio performance to separate digital and analog sections to prevent digital noise from effecting the performance of the analog circuits. The analog section of the CRD4201-2 is

completely isolated from the digital section with a 100 mil partition. Partitioning is defined as the absence of copper on all signal layers. The analog and digital sections each have their own separate ground planes. All analog components, power traces, and signal traces are routed over the analog ground plane. Digital components, power traces and signal traces are not allowed to crossover into the analog section.

The CS4201 audio codec is placed at the transition point between the analog and digital ground planes. The pins are arranged on the CS4201 so that the analog and digital signals are separated from each other. *The analog and digital ground planes must be tied together for the CS4201 to maintain proper voltage references.* For best results, the two ground planes are tied together with a single 50 mil trace under the CS4201 near its digital ground pins.

Data converters are generally susceptible to noise on the crystal pins. In order reduce noise from coupling onto these pins, the area around the 24.576 MHz crystal and its signal traces is filled with copper on the top and bottom of the PCB and attached to digital ground.

A separate chassis ground provides a noise-free reference point for all of the EMI suppression components. The chassis ground plane is connected to the analog ground plane at the external jacks.

3.2 CS4201 Layout Notes

Refer to the *CS4201 Data Sheet* for analog and digital partitioning guidelines and bypass capacitors placement. Pay special attention to the bypass capacitors on REFFLT, AFLT1, AFLT2 and the power supply capacitors.

4. REFERENCES

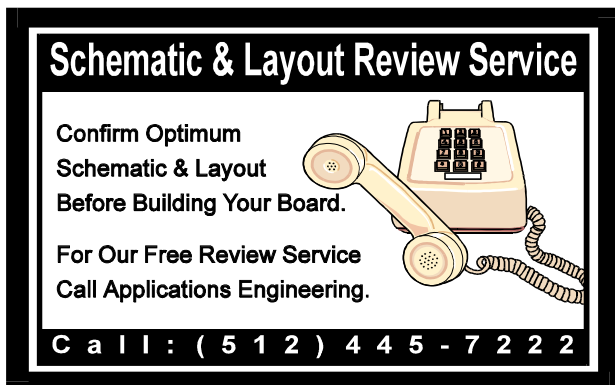

- 1) Intel[®], Audio Codec '97 Component Specification, Revision 2.1, May 22, 1998.
<http://developer.intel.com/ial/scalableplatforms/audio/>
- 2) ACR Special Interest Group, ACR Specification 1.0
<http://www.acrsig.org/>
- 3) Cirrus Logic, CS4201 Audio Codec '97 Data Sheet
<http://www.cirrus.com/products>
- 4) Steve Harris, Clif Sanchez, Personal Computer Audio Quality Measurements, Version 1.0
<http://www.cirrus.com/pubs/meas100.pdf>
- 5) Microsoft, PC Design Guidelines,
<http://www.microsoft.com/hwdev/desguid/>
- 6) M. Montrose, Printed Circuit Board Design Techniques for EMC Compliance (2nd edition), IEEE Press, New York: 2000.

4.1 ADDENDUM

- Schematic drawings
- Layout drawings
- Bill of materials

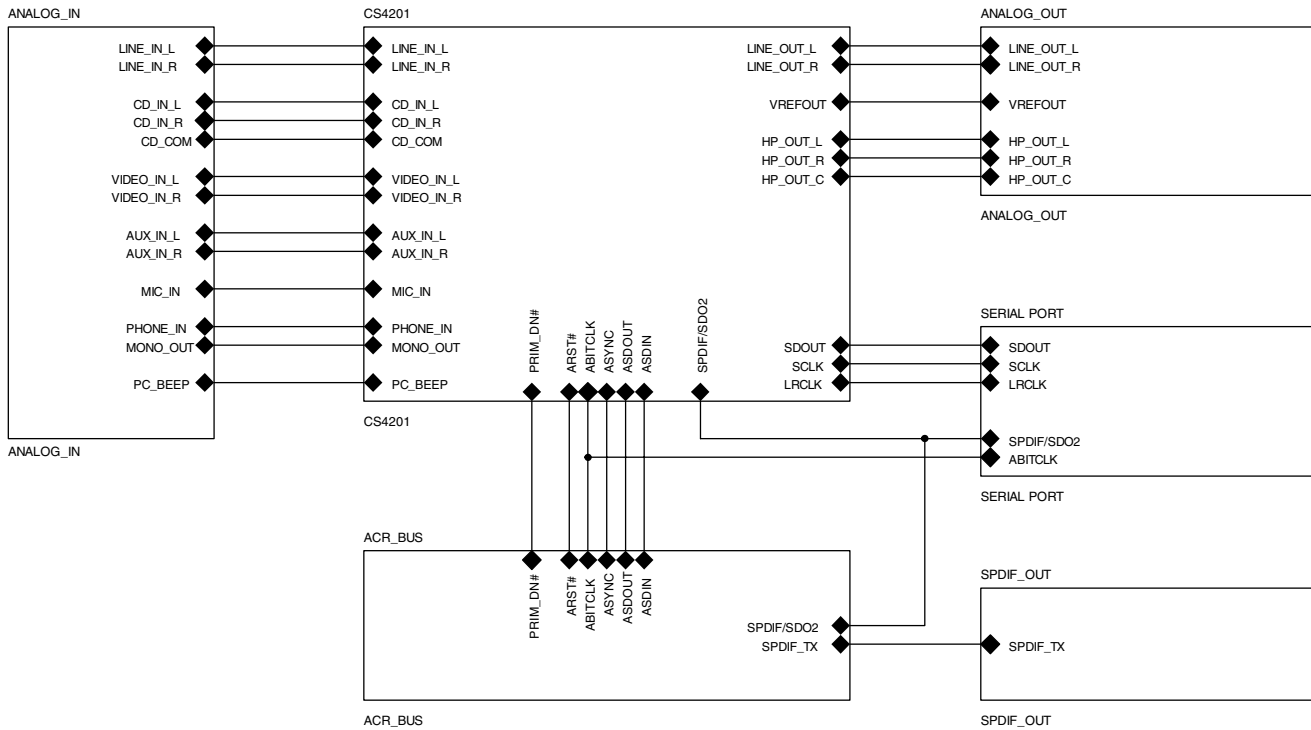

Figure 1. Block Diagram

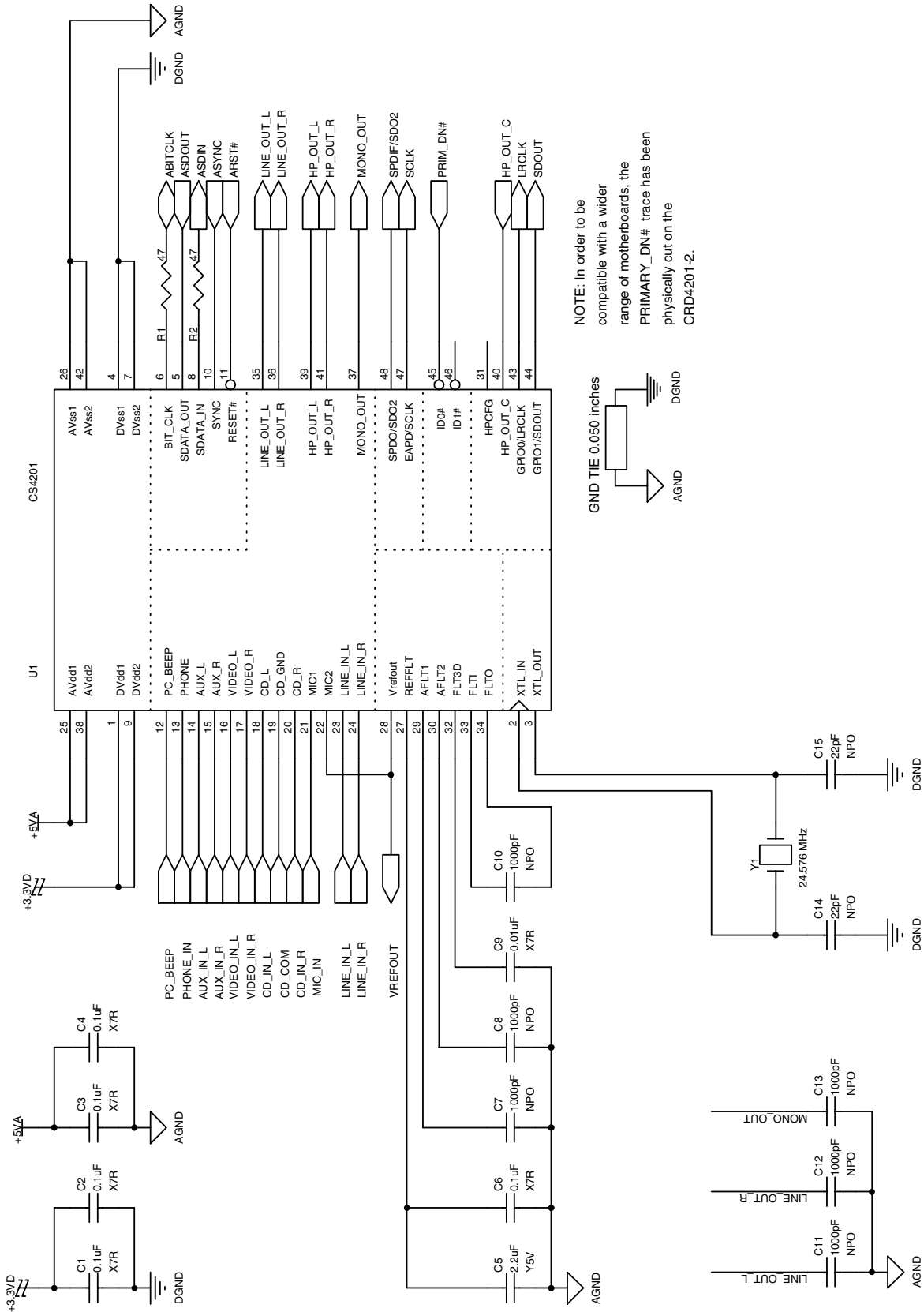

Figure 2. CS4201 Audio Codec

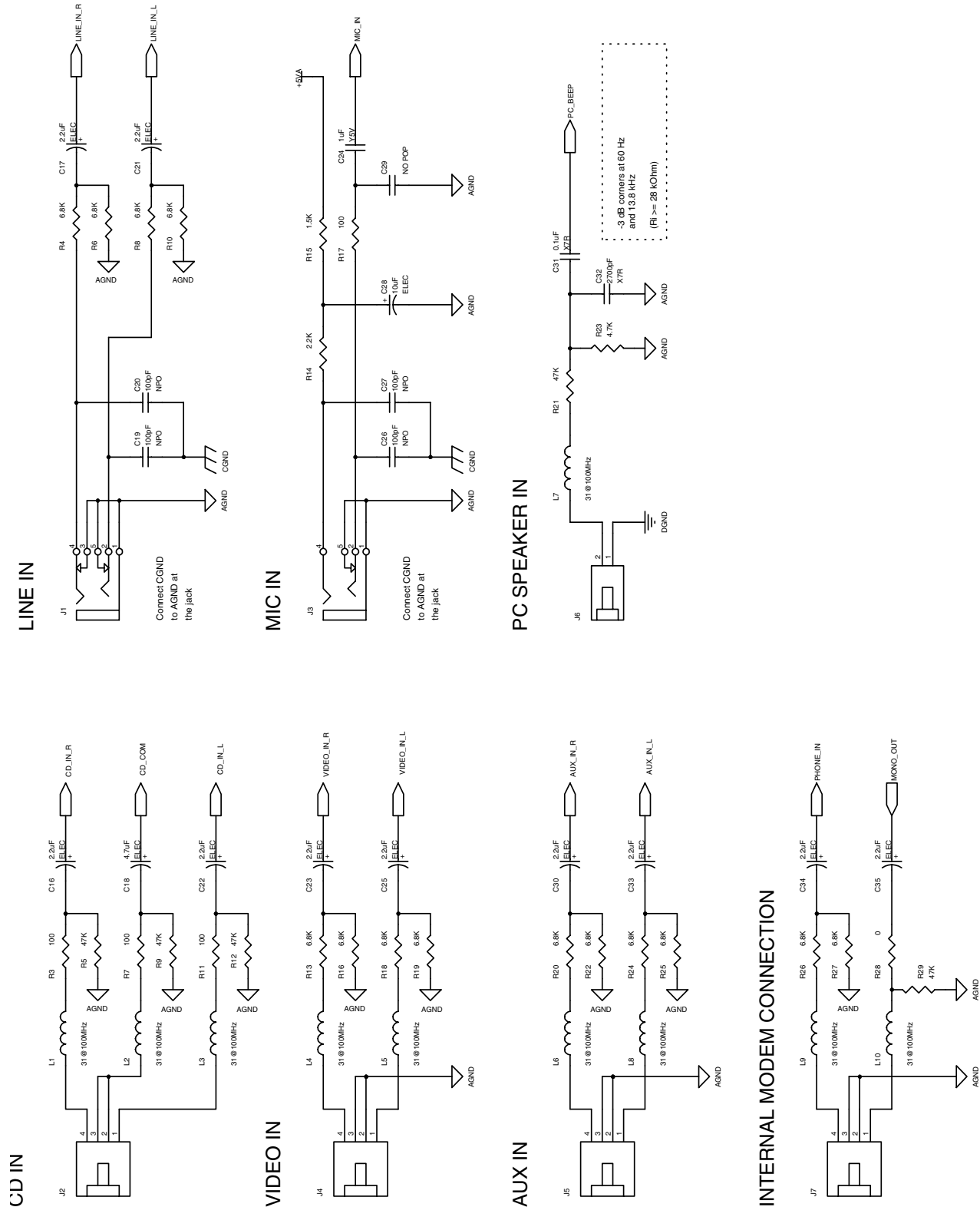

Figure 3. Analog Inputs

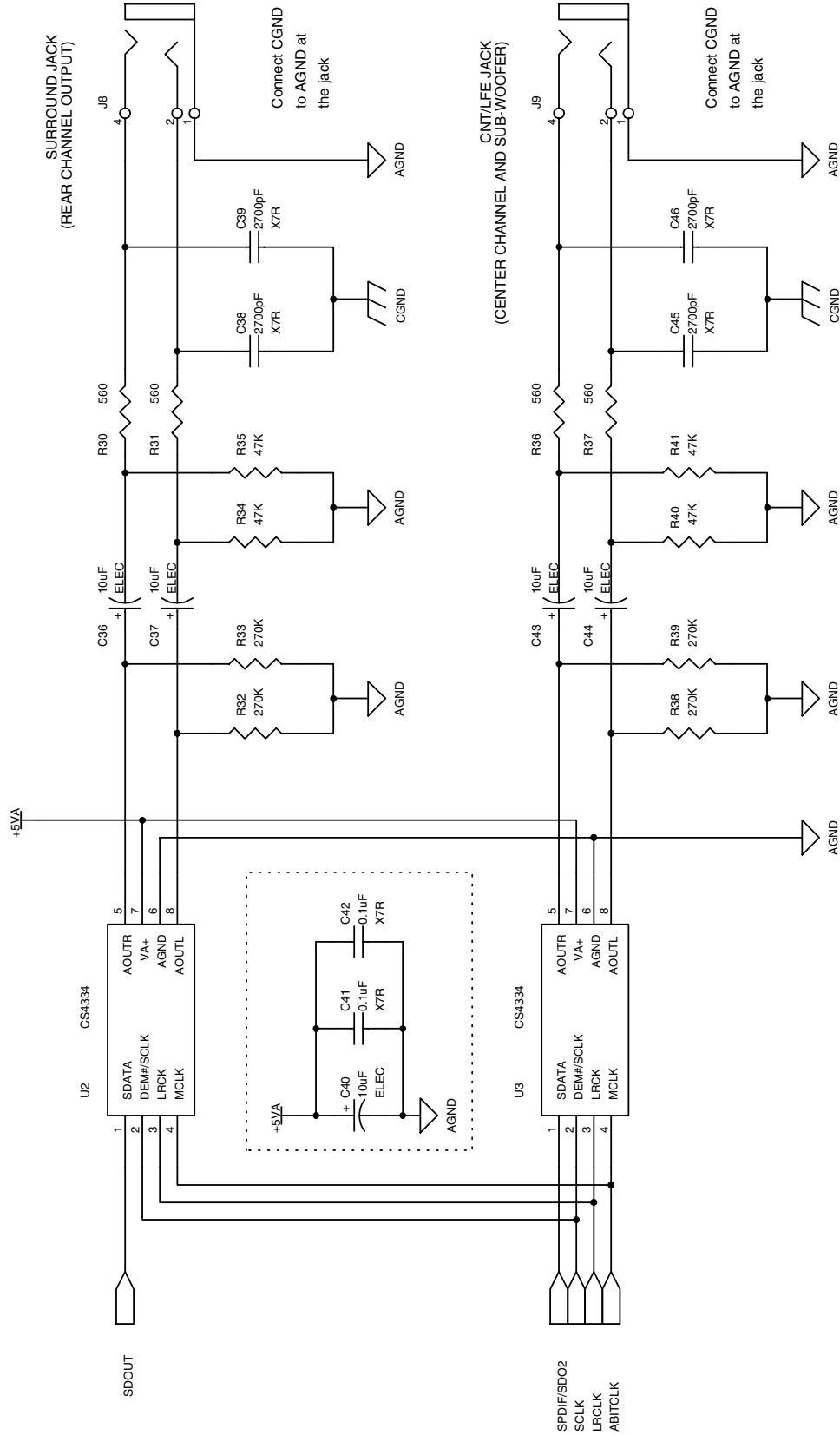

Figure 4. Rear, Center, and Sub-Woofers Outputs

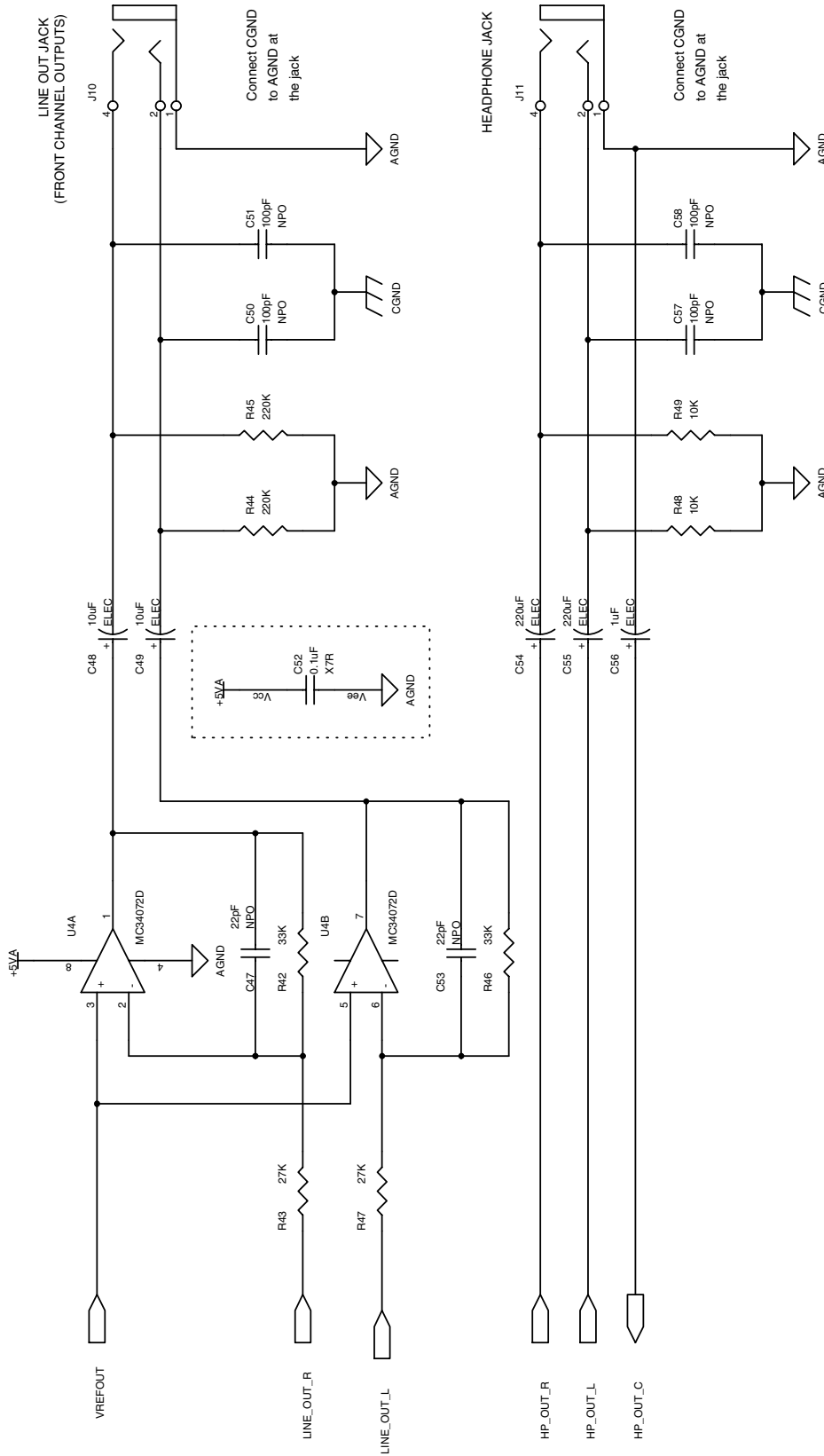

Figure 5. Front Channel and Headphone Outputs

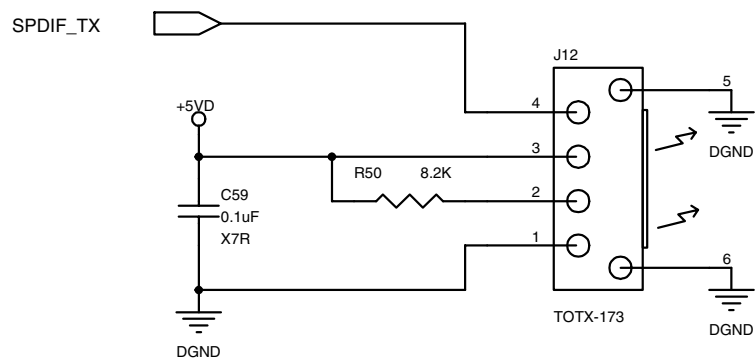

Figure 6. S/PDIF Optical Output

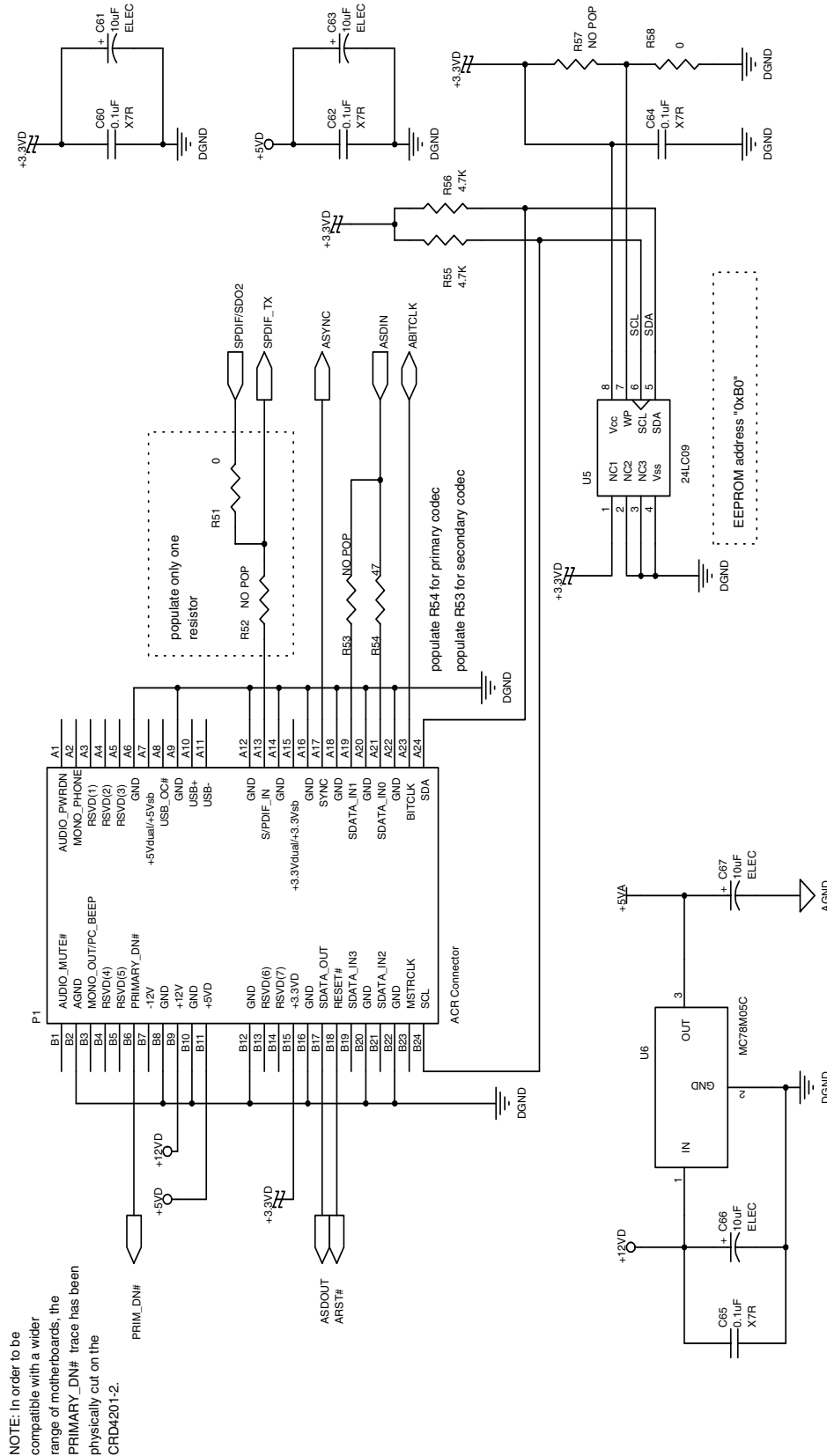

Figure 7. ACR Connector

NOTE: In order to be compatible with a wider range of motherboards, the PRIMARY_DN# trace has been physically cut on the CRD4201-2.

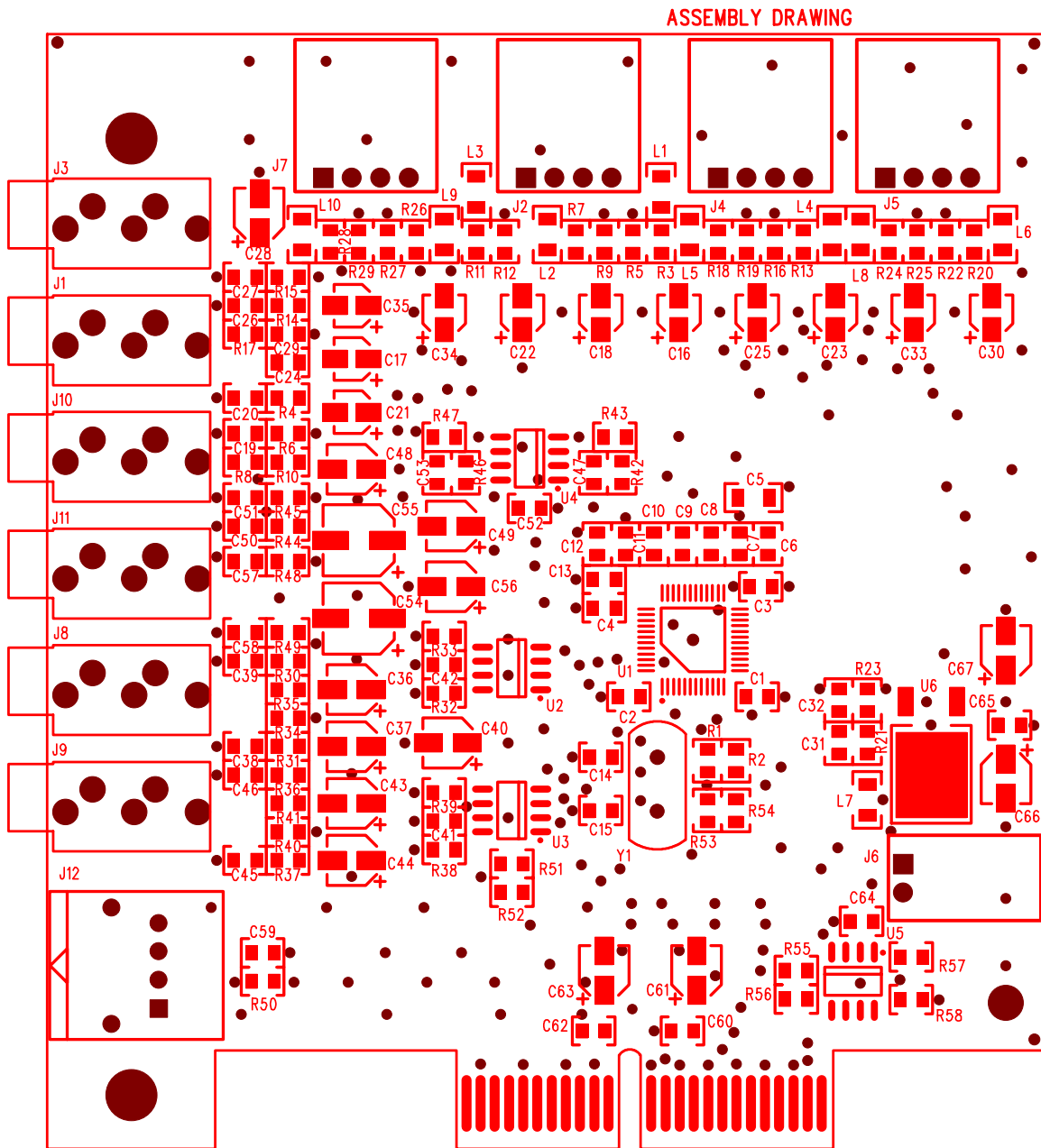

Figure 8. PCB Layout: Top Assembly Drawing

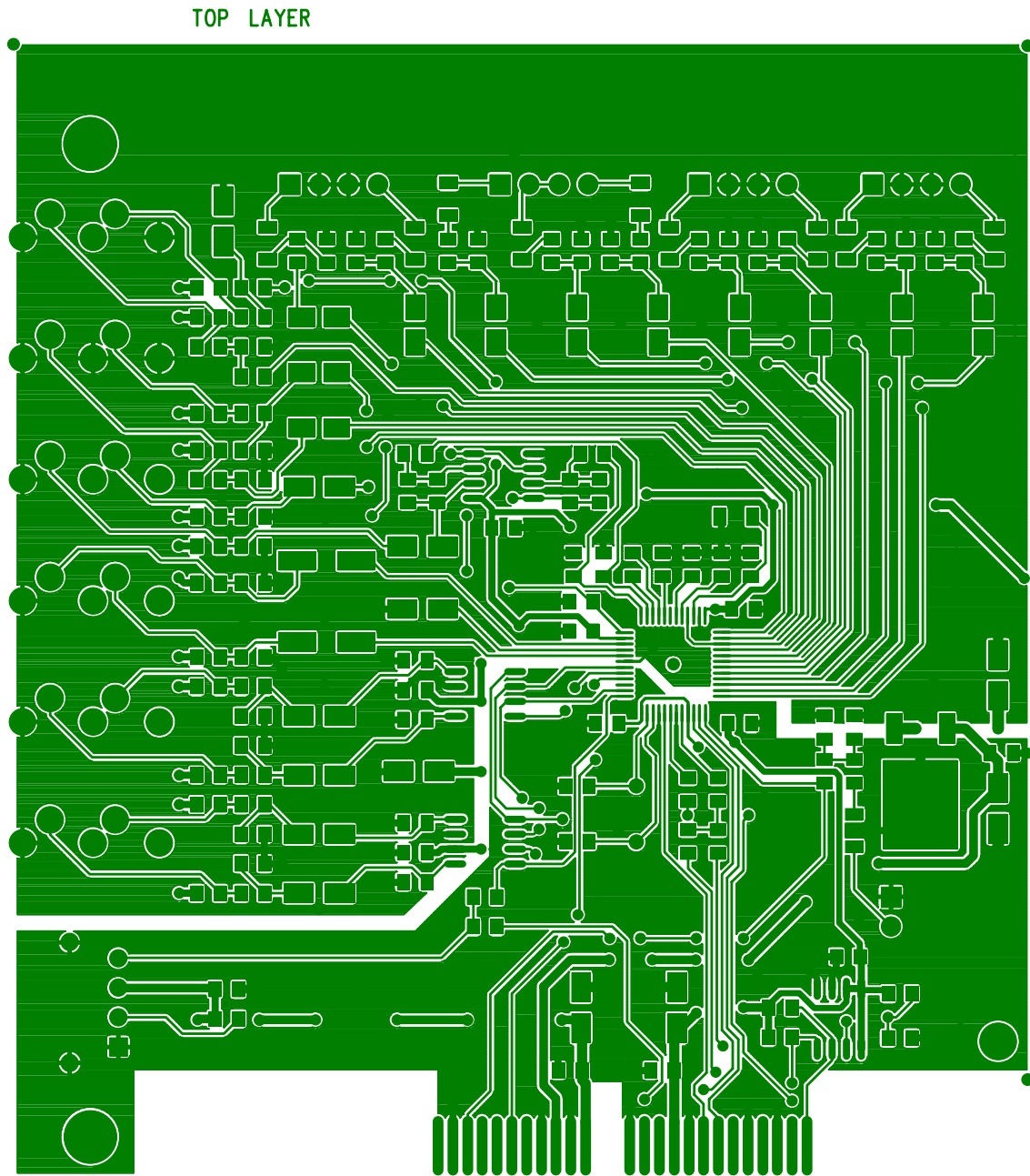
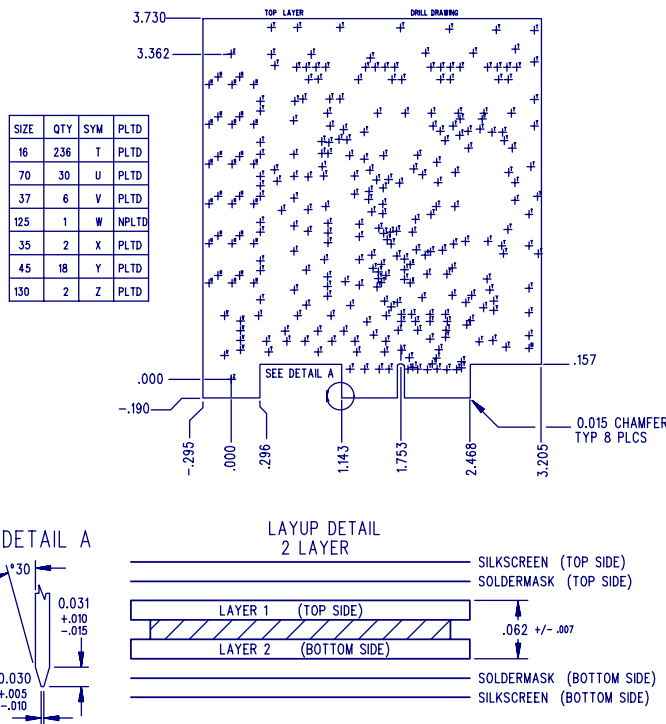

Figure 9. PCB Layout: Top Layer



Figure 10. PCB Layout: Bottom Layer



14. SURFACE MOUNT PAD SOLDER PLATING MUST BE FLAT TO A MAXIMUM OF .003" ABOVE BOARD SURFACE.
13. PLATE EDGE CONNECTOR, .00003" MINIMUM GOLD THICKNESS OVER .0002" MINIMUM LOW STRESS NICKEL.
12. .060" MAXIMUM RADIUS ON ALL INSIDE CORNERS.
11. DIMENSIONS AND TOLERANCES PER ANSI Y14.5M.
10. FABRICATE IN ACCORDANCE WITH IPC-ML-950C, CLASS 2.
9. BOARD SHALL MEET THE REQUIREMENTS OF UL796 WITH A FLAMMABILITY RATING OF 94V-0. VENDOR'S UL LOGO OR DESIGNATION SHALL BE LOCATED ON SOLDER SIDE OF BOARD.
8. REMOVE ALL BURRS AND BREAK SHARP EDGES .015 MAX.
7. SILKSCREEN COMPONENT SIDE USING WHITE EPOXY INK.
6. WARP OR TWIST OF BOARD SHALL NOT EXCEED .010 INCH PER INCH.
5. APPLY SOLDERMASK OVER BARE COPPER. SOLDERMASK TO BE PER IPC-SM-840, TYPE A, CLASS 3, COLOR: TRANSPARENT BLUE. ALL EXPOSED CONDUCTIVE SURFACES TO BE SOLDER COATED.
4. CONDUCTOR WIDTHS AND SPACING SHALL BE WITHIN +/- 20% OF ARTWORK ORIGINALS.
3. ALL HOLES SHALL BE LOCATED WITHIN .003" DIAMETER OF TRUE POSITION. LAYER TO LAYER REGISTRATION SHALL BE WITHIN .003". ALL HOLES SURROUNDED BY LAND SHALL HAVE A MINIMUM ANNULAR RING OF .003.
2. UNLESS OTHERWISE SPECIFIED ALL HOLE DIMENSIONS APPLY AFTER PLATING. ALL PLATED THROUGH HOLES TO HAVE A MINIMUM OF .001" COPPER.
1. MATERIAL: COPPER CLAD PLASTIC SHEET PER MIL-P-1394/4 GFN FINISHED COPPER WEIGHT SHALL BE 1 OZ. COPPER ON INTERNAL SIGNAL LAYERS, 2 OZ. COPPER ON PLANE LAYERS, OUTER LAYERS TO BE 1 OZ. FINISHED. LAMINATE USING PRE-PREG MATERIAL PER MIL-P-13949/12, TYPE PC-GF. OVERALL BOARD THICKNESS TO BE .062 +/- .007

NOTES: UNLESS OTHERWISE SPECIFIED

Figure 11. PCB Layout: Drill Drawing

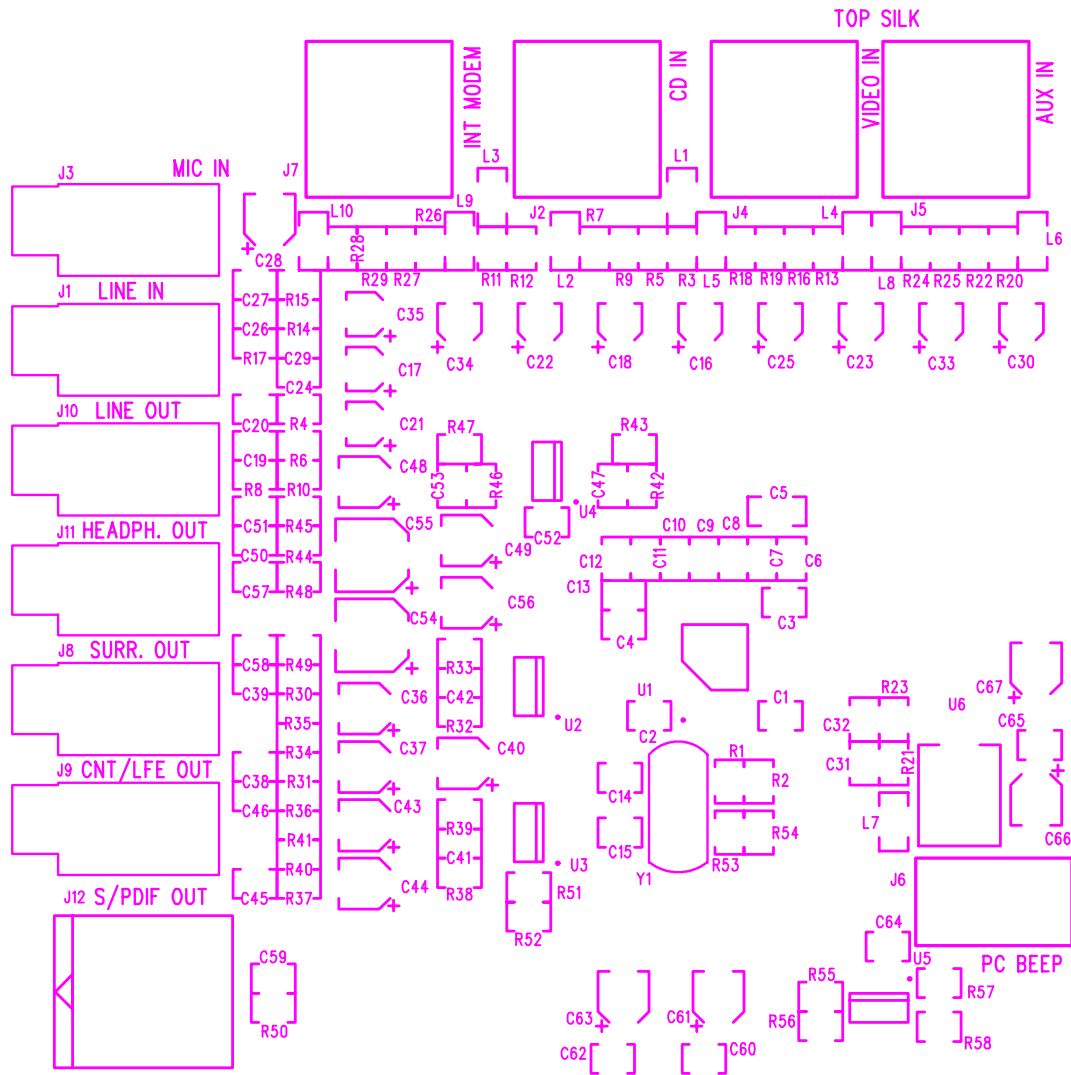

Figure 12. PCB Layout: Top Silkscreen

5. BILL OF MATERIALS

Item	Quantity	Reference	Manufacturer	Part Number	Description
1	14	C1,C2,C3,C4,C6,C31,C41, C42,C52,C59,C60,C62,C64, C65	KEMET	C0805C104K5RAC	CAP, 0805, X7R, .1uF, 10%, 50V
2	1	C5	KEMET	C1206C225M8VAC	CAP, 1206, Y5V, 2.2uF, 20%, 10V
3	6	C7,C8,C10,C11,C12,C13	KEMET	C0805C102K5GAC	CAP, 0805, C0G, 1000pF, 10%, 50V
4	1	C9	KEMET	C0805C103K5RAC	CAP, 0805, X7R, .01uF, 10%, 50V
5	4	C14,C15,C47,C53	KEMET	C0805C220K5GAC	CAP, 0805, C0G, 22pF, 10%, 50V
6	10	C16,C17,C21,C22,C23,C25, C30,C33,C34,C35	PANASONIC	ECE-V1VS2R2SR	CAP, SMT A, ELEC, 2.2uF, 20%, 35V
7	1	C18	PANASONIC	ECE-V1ES4R7SR	CAP, SMT A, ELEC, 4.7uF, 20%, 25V
8	4	C19,C20,C26,C27	KEMET	C0805C101J5GAC	CAP, 0805, C0G, 100pF, 5%, 50V
9	1	C24	KEMET	C0805C105M8VAC	CAP, 0805, Y5V, 1uF, 20%, 10V
10	12	C28,C36,C37,C40,C43,C44, C48,C49,C61,C63,C66,C67	PANASONIC	ECE-V1CA100R	CAP, SMT B, ELEC, 10uF, 20%, 16V
11	1	C29	NO POP	NO POP	NO POP
12	5	C32,C38,C39,C45,C46	KEMET	C0805C272K5RAC	CAP, 0805, X7R, 2700pF, 10%, 50V
13	4	C50,C51,C57,C58	KEMET	C0805C101J5GAC	CAP, 0805, C0G, 100pF, 5%, 50V
14	2	C54,C55	PANASONIC	ECE-V0GA221P	CAP, SMT D, ELEC, 220uF, 20%, 4V
15	1	C56	PANASONIC	ECE-V1HA010R	CAP, SMT B, ELEC, 1uF, 20%, 50V
16	1	J1	LZR ELECTRONICS	SJ372	CONN, 1/8" DOUBLE SW. STEREO PHONE JACK
17	4	J2,J4,J5,J7	MOLEX	70553-0003	HDR, 4X1, 0.025" PIN, 0.1" CTR, 15u" AU
18	1	J3	LZR ELECTRONICS	SJ374	CONN, 1/8" SINGLE SW. STEREO PHONE JACK
19	1	J6	MOLEX	70553-0036	HDR, 2X1, 0.025" PIN, 0.1" CTR, 150u" SN/PB
20	4	J8,J9,J10,J11	LZR ELECTRONICS	SJ373	CONN, 1/8" NON-SW. STEREO PHONE JACK

21	1	J12	TOSHIBA	TOTX173	CONN, OPTICAL TOSLINK TRANSMITTER
22	10	L1,L2,L3,L4,L5,L6,L7,L8, L9,L10	TDK	HF50ACB321611-T	IND, FBEAD, 1206, 31@100MHZ, 25%
23	1	P1	NONE	EDGE CONNECTOR	ACR BUS CONNECTOR
24	3	R1,R2,R54	PHILIPS	9C08052A47R0J	RES, SO, 0805, 47, 5%, 1/10W, METAL FILM
25	4	R3,R7,R11,R17	PHILIPS	9C08052A1000J	RES, SO, 0805, 100, 5%, 1/10W, METAL FILM
26	14	R4,R6,R8,R10,R13,R16,R18, R19,R20,R22,R24,R25,R26, R27	PHILIPS	9C08052A6801F	RES, SO, 0805, 6.8K, 1%, 1/10W, METAL FILM
27	9	R5,R9,R12,R21,R29,R34, R35,R40,R41	PHILIPS	9C08052A4702J	RES, SO, 0805, 47K, 5%, 1/10W, METAL FILM
28	1	R14	PHILIPS	9C08052A2201J	RES, SO, 0805, 2.2K, 5%, 1/10W, METAL FILM
29	1	R15	PHILIPS	9C08052A1501J	RES, SO, 0805, 1.5K, 5%, 1/10W, METAL FILM
30	3	R23,R55,R56	PHILIPS	9C08052A4701J	RES, SO, 0805, 4.7K, 5%, 1/10W, METAL FILM
31	3	R28,R51,R58	PHILIPS	9C08052A0R00J	RES, SO, 0805, 0, 5%, 1/10W, METAL FILM
32	4	R30,R31,R36,R37	PHILIPS	9C08052A5600J	RES, SO, 0805, 560, 5%, 1/10W, METAL FILM
33	4	R32,R33,R38,R39	PHILIPS	9C08052A2703J	RES, SO, 0805, 270K, 5%, 1/10W, METAL FILM
34	2	R42,R46	PHILIPS	9C08052A3302F	RES, SO, 0805, 33K, 1%, 1/10W, METAL FILM
35	2	R43,R47	PHILIPS	9C08052A2702F	RES, SO, 0805, 27K, 1%, 1/10W, METAL FILM
36	2	R45,R44	PHILIPS	9C08052A2203J	RES, SO, 0805, 220K, 5%, 1/10W, METAL FILM
37	2	R48,R49	PHILIPS	9C08052A1002J	RES, SO, 0805, 10K, 5%, 1/10W, METAL FILM
38	1	R50	PHILIPS	9C08052A8201J	RES, SO, 0805, 8.2K, 5%, 1/10W, METAL FILM
39	2	R52,R57	NO POP	NO POP	NO POP
40	1	R53	NO POP	NO POP	NO POP
41	1	U1	CIRRUS LOGIC	CS4201-JQ	IC, TQFP, AC '97 2.1 SERIAL CODEC W/ HP AMP + SRC

42	2	U2,U3	CIRRUS LOGIC	CS4334-KS	IC, SO, SOIC8, DAC, STEREO
43	1	U4	MOTOROLA	MC34072D	IC, SO, SOIC8, 34072, SINGLE SUPPLY DUAL OP AMP
44	1	U5	Microchip	24LC09-I/SN	IC, SO, SOIC8, SERIAL EEPROM, 4 x 256 x 8
45	1	U6	MOTOROLA	MC78M05CDT	IC, SO, +5V REGULATOR, DPAK, 4%, 500mA
46	1	Y1	FOX	FS24.576	XTAL, 24.576MHz, HC49S, Fund Mode, Par Res

SMART
Analog™